

# Kirkstall Family

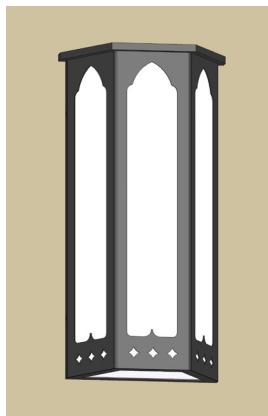

• PES 3217 •



• WES 3217 •

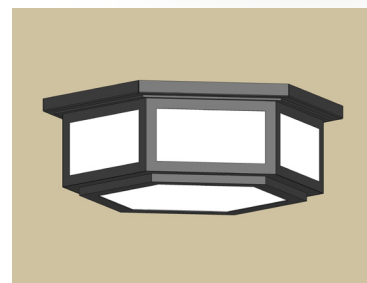

• CES 3503 •

*Kirkstall*

THE FIXTURES IN THIS FAMILY ARE CONSTRUCTED OF HEAVY GAUGE STEEL AND CAN BE FINISHED IN BLACK IRON PATINA OR ANY STANDARD PAINT FINISH. THE STANDARD LENSES ARE WHITE OR IVORY ACRYLIC PANELS.

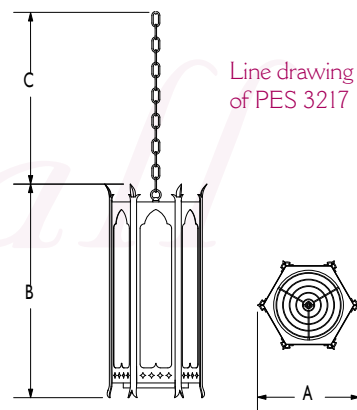

PENDANT:	CAT. NUMBER	DIAMETER A	HEIGHT B	HANGING C	LAMP CODE	LAMPING OPTIONS
	PES 3217	14.0"	28.5"	Specify	NA	6-75W A-19
					ND	6-75W A-19 + I-300W R40 down
					FA	4-40W compact fluorescent
					FD	4-40W compact fluorescent + I-300W R40 down
	PES 3218	17.0"	35.0"	Specify	NA	6-100W A-19
					ND	6-100W A-19 + I-500W R40 down
					FA	6-40W compact fluorescent
					FD	6-40W compact fluorescent + I-500W R40 down

CEILING:	CAT. NUMBER	DIAMETER	HEIGHT	LAMP CODE	LAMPING OPTIONS	
	CES 3503	18.5"	6.0"	-	NA	2-40W A-19
					FA	2-26W compact fluorescent
	CES 3504	24.0"	8.0"	-	NA	2-60W A-19
					FA	2-32W compact fluorescent

WALL:	CAT. NUMBER	WIDTH	HEIGHT	EXTENSION	LAMP CODE	LAMPING OPTIONS
	WES 3217	8.5"	17.5"	4.5"	NA	2-40W A-19
					FA	2-13W compact fluorescent
	WES 3218	10.5"	21.5"	5.5"	NA	2-60W A-19
					FA	2-18W compact fluorescent